











Strategic air-launched cruise missile Kh-101 with serial number "3152636174030", discovered on January 20, 2026









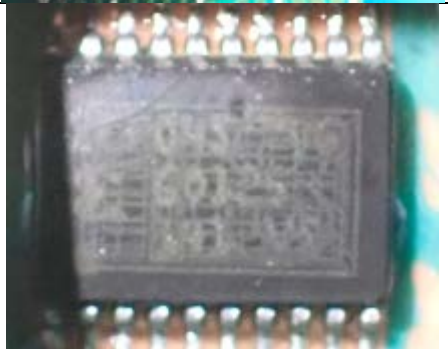

Enterprises/companies (countries of origin) that manufactured components/parts for the X-101 air-launched strategic cruise missile.

№	Name of component/part	Image of component/part	Enterprise/company (country of origin/manufacturing)





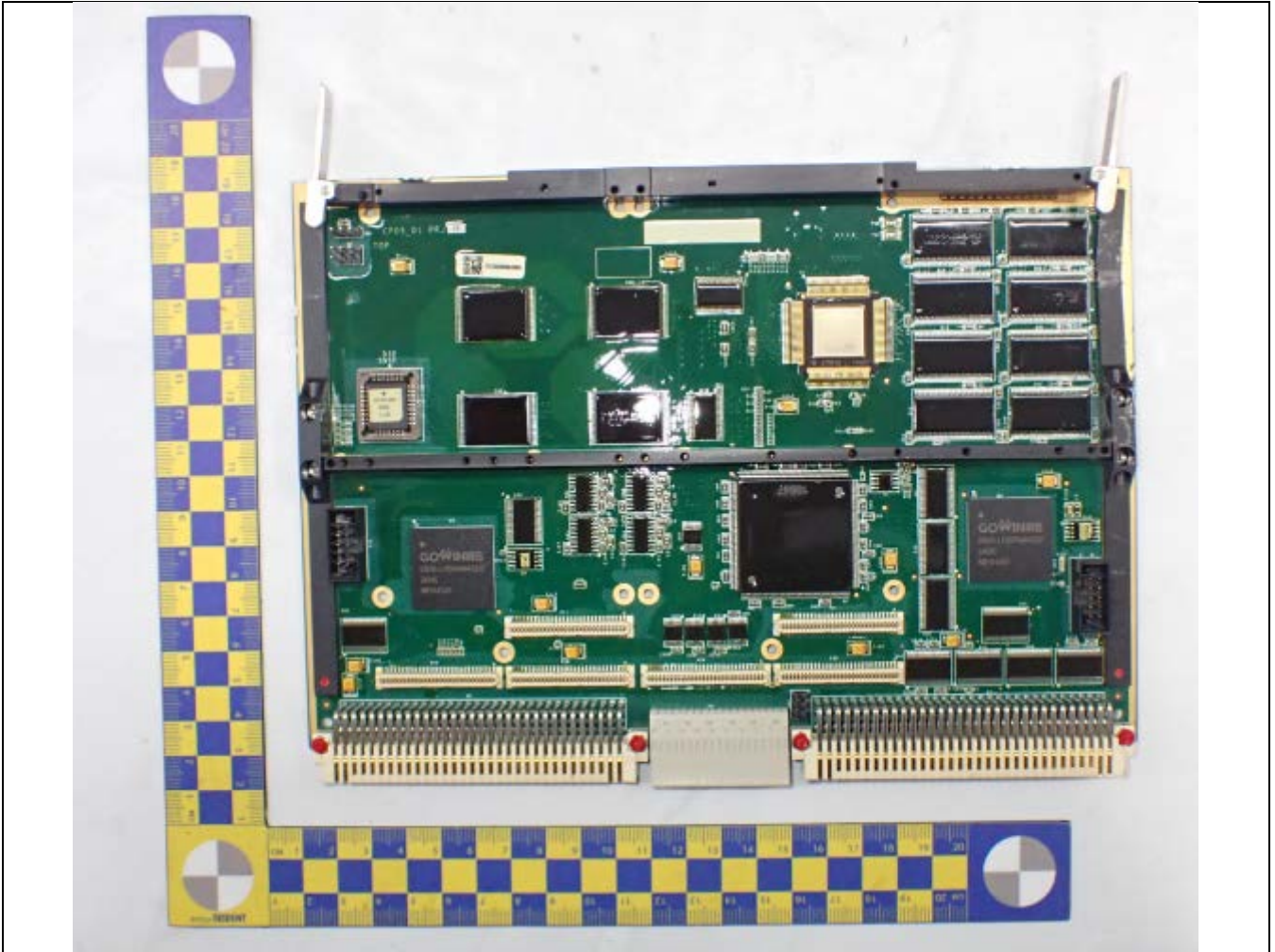



1.	RAM IS61WV20488FBLL-10T2LI		 Integrated Silicon Solution (ISSI) (USA) Manufactured by: (24) - 2024. (21) – 21st week.
2.	Microprocessor 1890VM2VT		 NICU "Kurchatov Institute" (Russia) Manufactured by: (24) - 2024. (34) – 34th week.
3.	Buffer/driver		 TEXAS INSTRUMENTS Texas Instruments (USA)
4.	Buffer/driver		 TEXAS INSTRUMENTS Texas Instruments (USA)
5.	XILINX chip		 XILINX XILINX (USA)  AMD (merged with AMD (Advanced Micro Devices), USA)

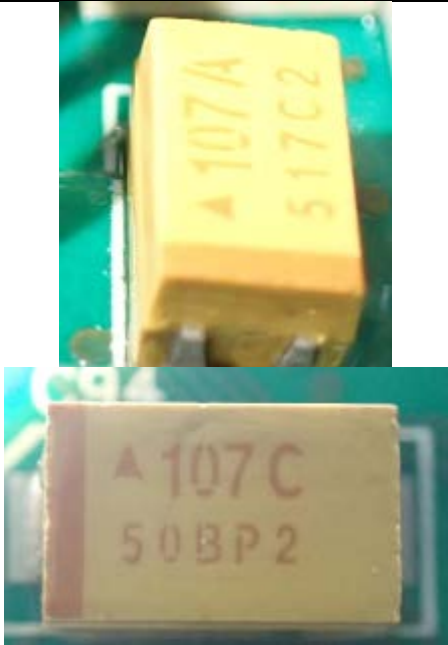







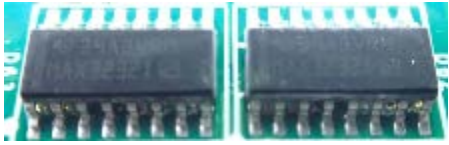

6.	Static RAM		<p>ALLIANCE (USA) Manufactured by: (24) – 2024; (01) – 1st week.</p>
7.	XILINX chip GQ125		<p> XILINX XILINX (USA)  (merged with AMD (Advanced Micro Devices), USA)</p>
8.	1533AP6 series chip		<p> JSC "Integral" (Republic of Belarus) Manufactured by: (25) – 2025; (26) – 26th week.</p>
9.	533TL2 series chip		<p> mikron ЭЛЕМЕНТ JSC "Mikron" (Russia) Manufactured by: (25) – 2025; (27) – 27th week.</p>







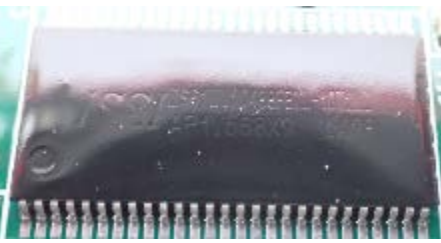

YUKSU.687265.535 v12.1.1 PCB

10.	Flash memory MX29GL256FHT2I-90Q		 <p>MACRONIX INTERNATIONAL CO., LTD. Macronix International (Taiwan)</p>
-----	------------------------------------	--	---

11.	Tantalum capacitor 107A 107C		 <p>Kyocera AVX components (USA)</p>
12.	Switching connector		 <p>The HARTING Technology Group (Germany) Manufactured by: (25) - 2025. (27) – 27th week.</p>
13.	Buffer/driver		 <p>TEXAS INSTRUMENTS Texas Instruments (USA)</p>
14.	Buffer/driver		 <p>TEXAS INSTRUMENTS Texas Instruments (USA)</p>

15.	Microcircuit		 TEXAS INSTRUMENTS Texas Instruments (USA)
16.	Microcircuit		 TEXAS INSTRUMENTS Texas Instruments (USA)
17.	LX125 chip 17K C33Y		 TEXAS INSTRUMENTS Texas Instruments (USA)
18.	Programmable Logic Integrated Circuit		 GOWIN Semiconductor (China) Manufactured by: (24) - 2024. (31) - 31st week.
19.	RAM		 Integrated Silicon Solution (ISSI) (USA) Manufactured by: (24) - 2024. (31) - 31st week.







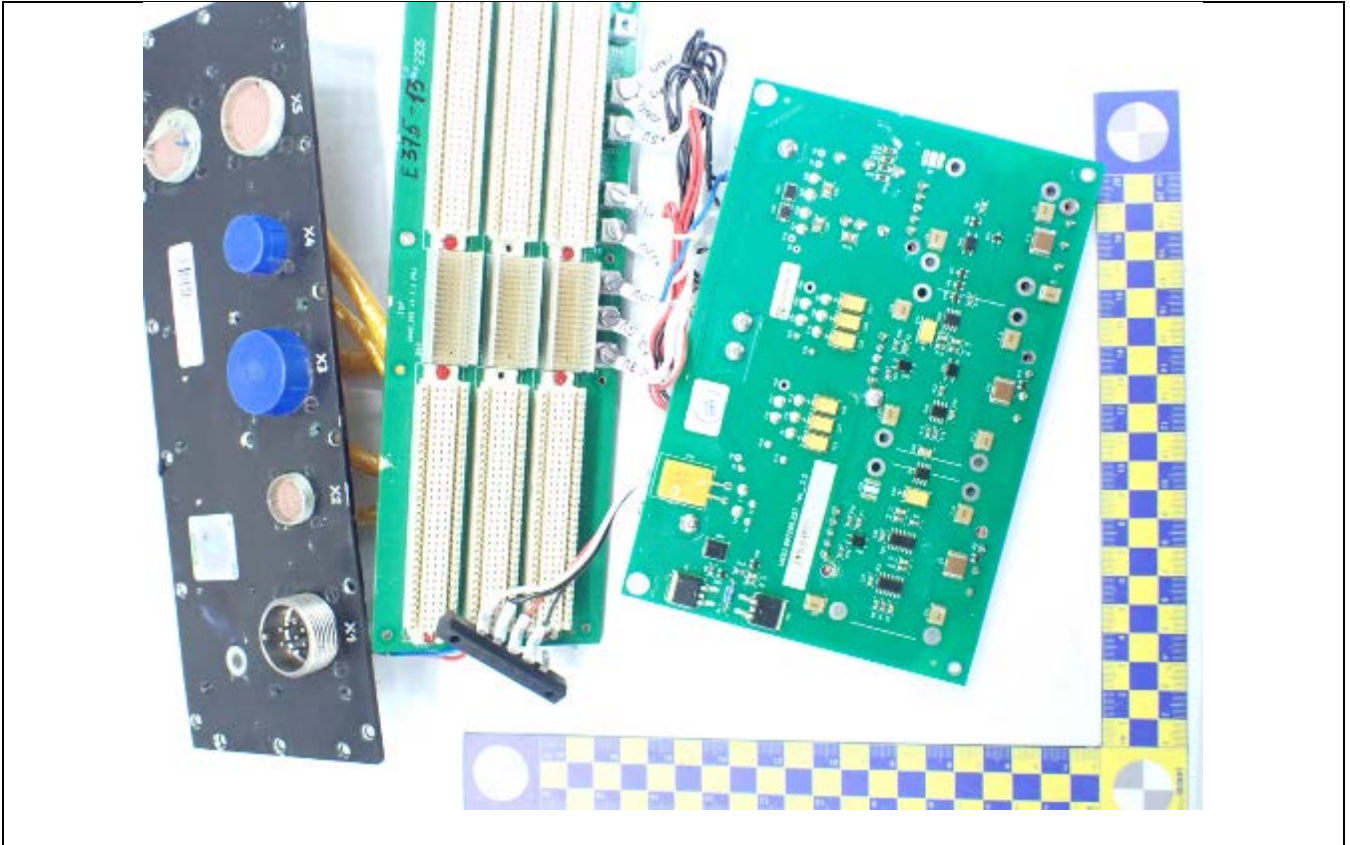



20.	RAM		 <p>Integrated Silicon Solution (ISSI) (USA) Manufactured by: (24) - 2024. (26) – 26th week.</p>
21.	Power inductor C 102		 <p>Coilcraft Country of brand registration: USA. The main headquarters are located in the USA, the UK and Taiwan.</p>
22.	Buffer/driver		 <p>TEXAS INSTRUMENTS Texas Instruments (USA)</p>

BOARD UKSU.687265.227







<p>23.</p>	<p>Relay</p>		<p>MORN SUN®</p> <p>MORN SUN Guangzhou Science & Technology Co., Ltd. (China) Manufactured by: (25) - 2025. (17) - 17th week.</p>
<p>24.</p>	<p>Voltage regulator</p>		<p>Vishay Intertechnology, Inc (USA)</p>

<p>25.</p>	<p>Surface-mount resistor network</p>		 <p>CTS Corporation (USA) Manufactured by: (23) - 2023. (18) – 18th week.</p>
<p>26.</p>	<p>Tantalum capacitor</p>		 <p>Vishay Intertechnology, Inc (USA)</p>
<p>27.</p>	<p>Switching connector</p>		 <p>The HARTING Technology Group (Germany) Manufactured by: (24) - 2024. (28) – 28th week.</p>
<p>28.</p>	<p>Transistor YJB100GP06H</p>		 <p>Yangzhou Yangjie Electronic Technology Co Ltd. (China)</p>
<p>29.</p>	<p>Tantalum capacitor</p>		 <p>General Semiconductor (USA) (owned by Vishay General Semiconductor)</p> 

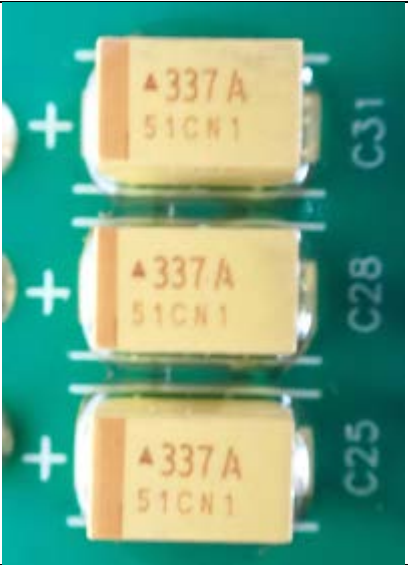





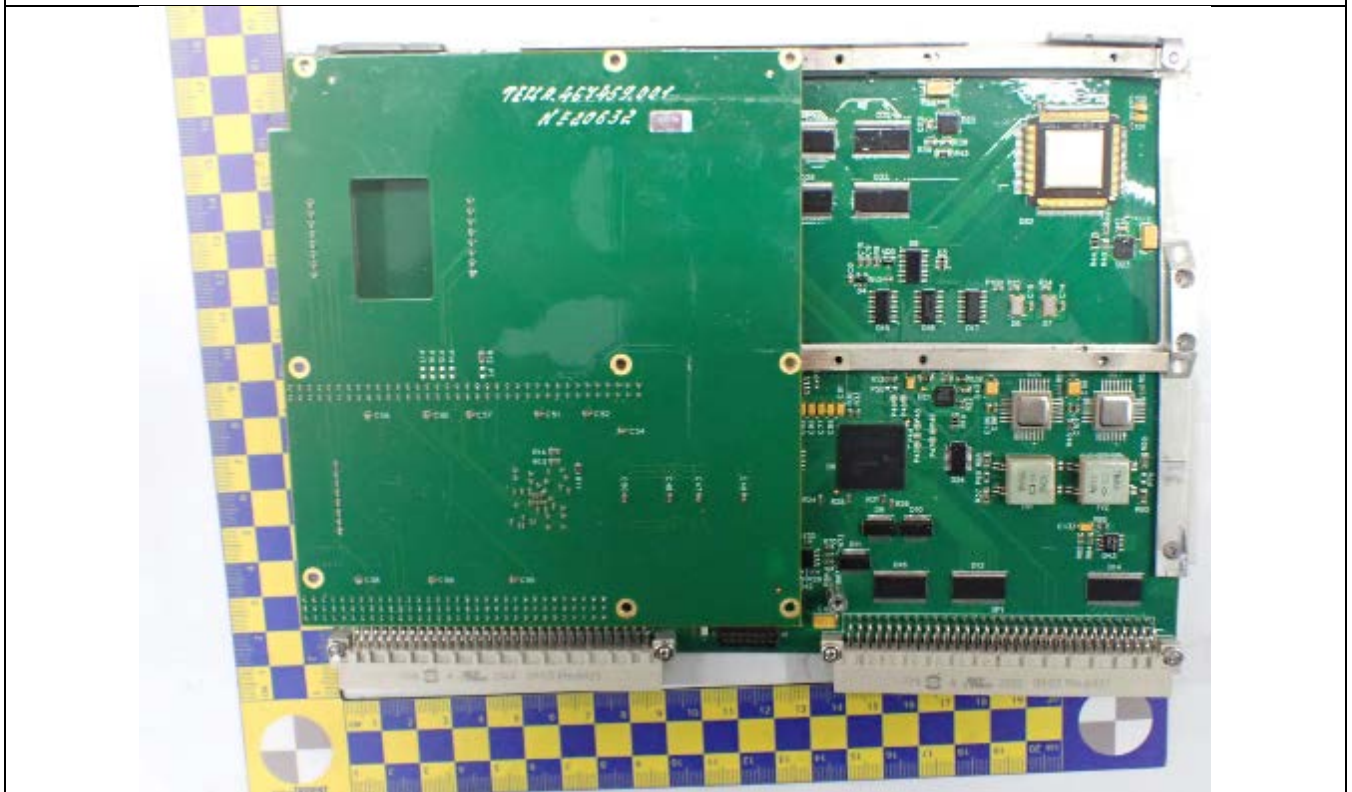



			Vishay Intertechnology, Inc (USA)
30.	Transceiver HEF4093BT		 Nexperia (Netherlands) (subsidiary of a Chinese corporation Wingtech Technology)  闻泰科技
31.	GF Multilayer Ceramic Chip Capacitor		 INNOVATOR IN ELECTRONICS Murata Manufacturing Co. Ltd (Japan)
32.	Transceiver ADM708 SUPPLY		 Analog Devices (USA) Manufactured by: (1) - 2021. (21) - 21st week







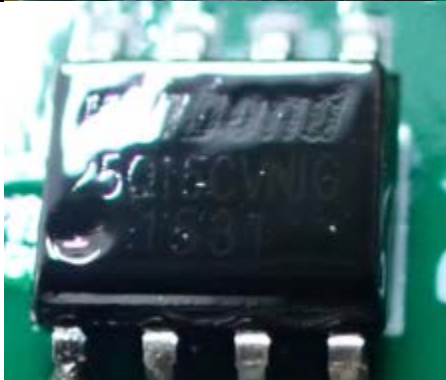



<p>33.</p>	<p>Tantalum capacitor</p>		 <p>Kyocera AVX components (USA)</p>
------------	---------------------------	--	--







MKR TECA BOARD.467415.001



<p>34.</p>	<p>Specialized microprocessor</p>		 <p>NICU "Kurchatov Institute" (Russia) Manufactured by: (24) - 2024. (19) – 19th week</p>
------------	-----------------------------------	--	--

<p>35.</p>	<p>RAM</p>		 <p>Integrated Silicon Solution (ISSI) (USA) Manufactured by: (20) - 2020. (24) – 24th week.</p>
<p>36.</p>	<p>Memory controller SPARTAN-6 XC6SLX16 FTG256DIV23</p>		 <p>XILINX (USA)  (merged with AMD (Advanced Micro Devices), USA) Manufacturer – TSMC (Taiwan) Manufactured in 2023.</p>
<p>37.</p>	<p>Memory controller SPARTAN-6 XC6SLX16 FTG256DIV23</p>		 <p>XILINX (USA)  (merged with AMD (Advanced Micro Devices), USA) Manufacturer – TSMC (Taiwan) Manufactured in 2023.</p>
<p>38.</p>	<p>Non-volatile flash memory 25Q16SCVN1G</p>		 <p>Winbond (Taiwan) Manufactured by: (15) - 2015. (31) – 31st week</p>

<p>39.</p>	<p>Flash memory S29AL016J70TFI010</p>		 <p>Spansion, Inc. (USA) Acquired by the company in 2020</p>  <p>Infineon Technologies (Germany)</p>
<p>40.</p>	<p>Stabilizer 1963A</p>		 <p>Linear Technology Corporation(part of Analog Devices since 2017) (USA)</p>
<p>41.</p>	<p>Four buffers/line driver 74ABT125D CXE41603</p>		 <p>Nexperia (Netherlands) (subsidiary of a Chinese corporation Wingtech Technology)</p>
<p>42.</p>	<p>Static RAM CY7C1051H30-10ZSXI</p>		 <p>Cypress Semiconductor (USA) Acquired by the company in 2020</p>  <p>Infineon Technologies (Germany) Manufactured by: (23) - 2023. (07) – 7th week</p>

<p>43.</p>	<p>High-precision reference voltage source</p>		 <p>Analog Devices (USA) Manufactured by: (2) - 2022. (37) – 37th week</p>
<p>44.</p>	<p>Linear driver HI-8588</p>		 <p>Holt Integrated Circuits, Inc. (USA) Manufactured by: (22) - 2022. (14) – 14th week</p>
<p>45.</p>	<p>Tantalum capacitor</p>		 <p>Kyocera AVX components (USA)</p>